

LED GARDEN LAMP

horoelectric.com.ua
+38 (096) 8312125

Product&Family Code: 076 019 0012

SUGA-12/RC



Technical Drawing

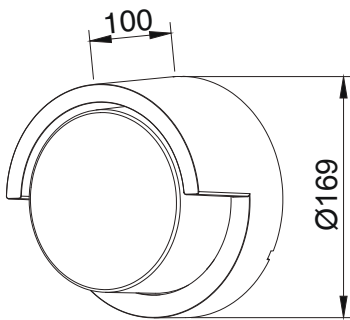

Technical Data

Voltage (V)	85-265V
Product Wattage (W)	12
Equivalence with incandescent lamp(W)	96
Colour Render Index (Ra)	>Ra70
Colour Temperature (K)	4200K
Materials	ABS
Protection Class	II
Dimmable	No
EEI	A to A++
Warm-up time up to 60 %of the full light output	Instant Full Light
Luminous Flux (lm)	700
Luminous Efficacy (lm/W)	58
Rated Life (hrs) ⌚	30.000
IP Rating	65
Power Factor	>0.5
Beam Angle	128°
Starting Time	<0.2s
Number of ON-OFF cycling	x15.000

Applications

- Designed Outdoor Applications: Hotel, home lighting, recreation place, supermarket, office building.

Features

- High Lumen and CRI, Good quality & Constant Current driver.
- High heat dissipation, low carbon and environmental protection.
- SMD LED Lamp Base.
- Innovative Design of Assembly Structure

