

ASLAN/S-50

LED PROJECTOR WITH SENSOR

Product Code: 068 011 0050



WITH PIR SENSOR

BLACK

Technical Drawing

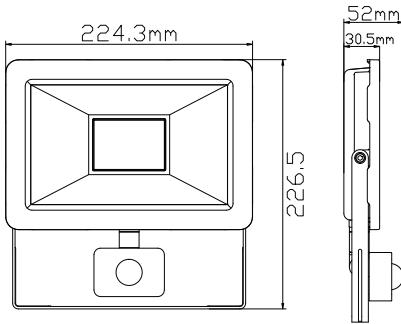

Photometric Diagram

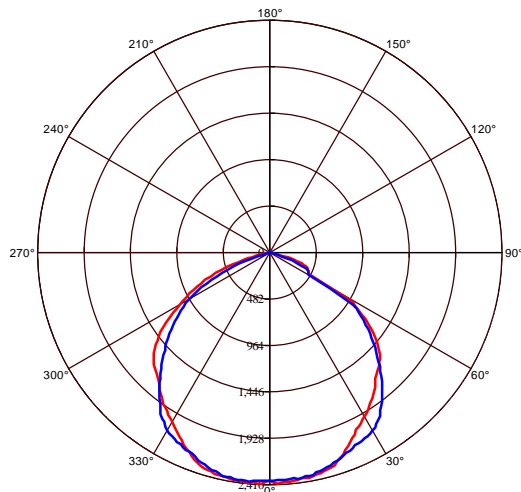

b C0 Plane beam angle(50%) b C90 Plane beam angle(50%)

C0 Plane beam angle(50%):111.8(DEG) C90 Plane beam angle(50%):107.9(DEG)

Technical Data	
Voltage (V)	175-250V
Product Wattage (W)	50
Equivalence with incandescent lamp(W)	400
Colour Render Index (Ra)	>Ra80
Colour Temperature (K)	2700K - 6400K - Green
Materials	Aluminium Die Casting Body
Protection Class	I
Dimmable	No
EEL	A to A++
Warm-up time up to 60 %of the full light output	Instant Full Light
Luminous Flux (lm)	4000
Luminous Efficacy (lm/W)	80
Rated Life (hrs) ⌚	30.000
IP Rating	65
Power Factor	>0.9
Beam Angle	120°
Starting Time	<0.2s
Number of ON-OFF cycling	x15.000
Detection Distance	2-8m
Duration Time	12sec~7min±2min

Applications

- Stadiums, Outdoor



Features

- High Lumen and CRI, Good quality & Constant Current driver.
- High heat dissipation, low carbon and environmental protection.
- SMD LED Lamp Base.
- Very low energy consumption.

